

SPECIALIST FLOW TRANSDUCERS

Technical Specifications:

The dB3 with Double Sun Shields and dBMACH3 transducers have been designed specifically for open channel flow measurement.



PHYSICAL: MODEL OPTION SPECIFIC

Model Option:	dBMACH3	dB3 with Double Sun Shields
Sensor Body Dimensions	180 mm D (sunshield) x 205 mm H (7.08 in x 8.1 in)	180 mm D (sunshield) x 115 mm H (7.08 in x 4.5 in)
Weight	Nominal 1.1 kg (2.4 lb)	Nominal 1.1 kg (2.4 lb)
Max. and Min. Temperature (Electronics)	Standard: -30 °C to +90 °C (-22 °F to +194 °F) ATEX: -30 °C to +75 °C (-22 °F to +167 °F)	Standard: -40 °C to +90 °C (-40 °F to +194 °F) ATEX: -40 °C to +75 °C (-40 °F to +167 °F)
Measurement Range	0 mm to 2.4 m (0 in to 7.9 ft)	125 mm to 3 m (4.9 in to 9.8 ft)
Accuracy	±1 mm (0.039 in)	0.25% or 6 mm (0.2 in) whichever is greater
Resolution	±0.5 mm (0.019 in)	0.01% or 2 mm (0.08 in) whichever is greater
MCERTS Certified	Not Applicable	Class 1 (0.193%) when used with FlowCERT Lite

PHYSICAL: BOTH TRANSDUCERS

Sensor Body Material	Valox 357 U and syntactic foam face
Cable Lengths	Standard = 5 m, 10 m, 20 m or 30 m (16.4 ft, 32.8 ft, 65.6 ft or 98.4 ft). Optional: up to 150 m (492 ft) maximum (increments of 10 m / 32.8 ft only)
Maximum Separation	500 m (1,640 ft)
Mounting Connection	BSP or 1" NPT

ENVIRONMENTAL

Enclosure Protection	IP68 / NEMA 6P
-----------------------------	----------------

APPROVALS

CE Approval	2014/30/EU - EMC & 2014/34/EU ATEX Directives. Standards applied: EN 60079-0:2012+A11:2013 / EN 60079-11:2012 / EN 60079-18:2009 / EN 60079-26:2007 / EN 61326-1:2013
ATEX Approval	Standard ATEX EEx m II T6 or optional EEx ia IIC T6. FM/FMC approval.

PERFORMANCE

Frequency	125kHz
Beam Angle	<10°

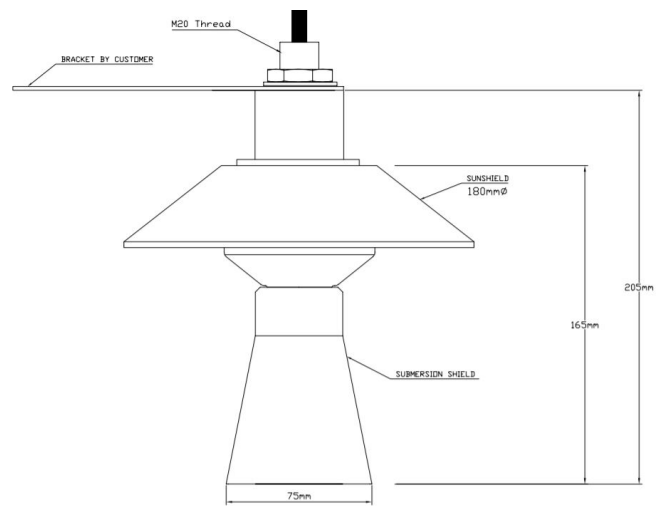

dBMACH3 Transducer Drawing

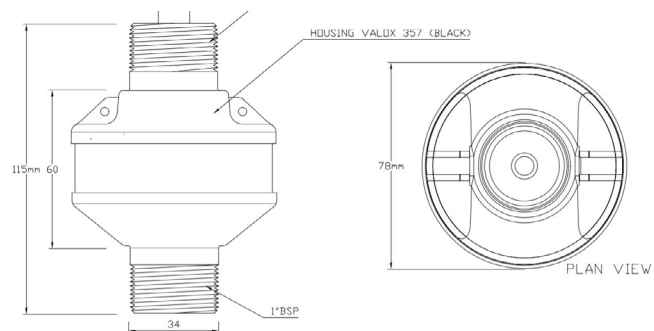

dB3 Transducer Drawing (not including Sun Shields)

Delivering the Measure of Possibility

Pulsar Measurement offers worldwide professional support for all of our products, and our network of global partners all offer full support and training. Our facilities in Malvern, UK and Largo, USA are home to technical support teams who are always available to answer your call or attend your site when required. Our global presence, with direct offices in the UK, USA, Canada, and Malaysia, allows us to create close relationships with our customers and provide service, support, training, and information throughout the lifetime of your product.

By taking a step forward in echo processing technology, Pulsar Measurement addresses applications previously thought to be beyond the scope of ultrasonic measurement. This technology improves signal processing at the transducer head which has made it possible to increase resistance to electrical noise, enabling the transducer to 'zone in' on the true echo.

For more information, please visit our website:

www.pulsarmeasurement.com



INFO@PULSARMEASUREMENT.COM

Pulsar Measurement is a trading name of Pulsar Process Measurement, Ltd.

*Copyright © 2020 Pulsar Measurement
Registered Address: 1 Chamberlain Square CS, Birmingham B3 3AX
Registered No.: 3345604 England & Wales*

United States

11451 Belcher Road South
Largo, FL 33773

+1 888-473-9546

Canada

16456 Sixsmith Drive
Long Sault, Ont. K0C 1P0

+1 855-300-9151

United Kingdom

Cardinal Building, Enigma
Commercial Centre
Sandy's Road, Malvern WR14 1JJ

+44 (0) 1684 891371

Rev 4.0